

USER MANUAL

# PROFESSIONAL

Wind Sensors



# Content

Warranty	2
Features of the PROFESSIONAL wind sensors	3
Initial operation	3
Selecting the place of installation	3
Mounting of the cup rotor at the wind speed sensor	4
Mounting options	4
Adjusting the wind vane to the north	5
Electrical connections	6
Heating	6
Maintenance	7
Disposal	7
Technical data - Cable	7
Dimensional drawings	8
Electrical connection	9
Technical data - Sensors	10

# Warranty

**Please note the loss of warranty and non-liability by unauthorized manipulation of the system. You need a written permission of the LAMBRECHT meteo GmbH for changes of system components. These activities must be operated by a qualified technician.**

The warranty does not cover:

1. Mechanical damages caused by external impacts (e. g. icefall, rockfall, vandalism).
2. Impacts or damages caused by over-voltages or electromagnetic fields which are beyond the standards and specifications in the technical data.
3. Damages caused by improper handling, e. g. by wrong tools, incorrect installation, incorrect electrical installation (false polarity) etc.
4. Damages which are caused by using the device beyond the specified operation conditions.



## Features of the PROFESSIONAL wind sensors

- PROFESSIONAL wind sensors for determining wind direction and wind speed
- Integrated, controlled heating for optimum heating of the sensor head, thermally separated from the lower housing part
- Double ball bearing of the measuring elements on the rotary axes causes low friction, very low wear and therefore high reliability and durability
- Dimensionally stable blade vane and break-proof three-armed cup rotor made of seawater-resistant aluminum for maximum load-bearing capacity
- Simple mounting principles for mast, flange or bore for a high degree of flexibility
- Sensors with plug-in cable connection, particularly useful for easy installation or service work

## Initial operation

The wind can be represented by a vector quantity. For a complete description of the wind it is necessary to specify its speed and direction. The two components are subject to spatial and temporal variations; thus, strictly speaking, they are valid only for the site where the measuring instrument is put up. We therefore recommend to select the place of installation very carefully.

## Selecting the place of installation

Generally, wind measuring instruments should not measure the specific wind conditions of a limited area, but indicate the typical wind conditions of a wider area. The values measured at different places must be comparable. Thus, when installing the sensor you should make sure the place of installation is not under the lee of great obstacles. The distance between the obstacles and the sensor should be 10 times the height of the obstacles (this corresponds to the definition of an undisturbed terrain).

If there is no *undisturbed terrain*, the sensor must be set up at a height that exceeds the height of the obstacle by at least 5 m. If the sensor must be installed on a roof top the place of installation must be in the middle of the roof to avoid predominant wind directions.

If you want to measure both wind direction and wind speed, install the sensors at the same measuring point, if possible, and make sure to avoid any mutual influence of the sensors. A wind sensor pair easily meets this requirement since the sensors are set up side by side. Their horizontal distance should be approximately 1.5 m. The two sensors must be staggered vertically so that the lower edge of the upper wind speed sensor is 0.1 to 0.5 m above the upper edge of the lower wind direction sensor.

## Mounting of the cup rotor at the wind speed sensor

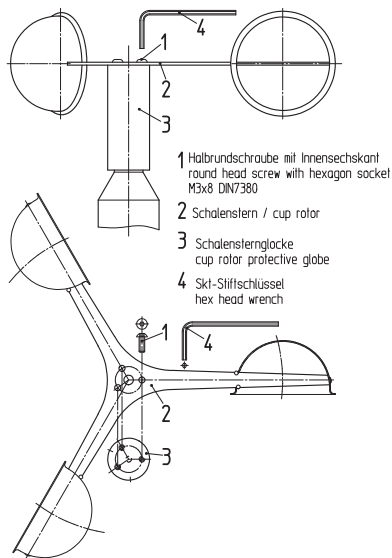

The bores at the cup rotor are so attached that the cup rotor can only in a certain, clear position to be installed. All three screws must be used and the cup rotor with it be fastened. Thus the correct direction of rotation is guaranteed. The necessary wrench is included in delivery.

## Mounting options



Since installation usually takes place at great heights, the assembly personnel must observe the relevant safety regulations during installation.

### I. MAST OR PIPE MOUNTING



Make sure the device is easily accessible so that you can set up the north direction for the wind direction sensor and perform any maintenance work. To reach the sensors use a ladder of the appropriate length or a telescoping working platform of the appropriate height.



Ladders or other lifting helps must be absolutely in order and must be guarantee a secure support! Follow the rules for prevention of accidents.

Mast or tube (grounded) have an outer  $\varnothing$  of 48-50 mm. A mast adapter (see accessories) is required.

1. Loosen both threaded nuts from the sensor.
2. The sensor with cable plug connection is inserted into the hole ( $\varnothing$  30 mm) of the adapter without cable.
3. To fasten the sensor, one of the loosened threaded nuts is screwed from below with the flat side onto the sensor thread against the inner surface of the adapter, tightened with a suitable tool (SW 36) until there is resistance to twisting of the aligned sensor.
4. Finally, it is recommended that the second threaded nut also be countered against the first threaded nut with the flat side first.

You can also use masts that can turn around their vertical axis or masts consisting of individual segments or telescoping masts that you can secure after setting up the north direction.



If wind speed and wind direction are measured at the same time, the measurement generally takes place not only at the top of a mast but also at the ends of a cross arm. The arms must stay torsion-free and vibration-proof even at high wind speeds and they must be accessible for you to perform mounting and maintenance work.



When you install the connecting cables make sure not to excessively shorten the cable leading to the connector in the lower part of the sensor casing so that you can later maintain or dismounting the sensor. Put further a cable loop as sensor protection against water under the sensor.



Tip: Install the sensors on ground to the traverse and align you the wind vane parallel to the traverse. You go only then upward, in order to accordingly align the sensors with traverse under assistance of a partner on ground.

## II. TRAVERSE WITH BORE

(Id-no.: 32.14567.010 000)

At the traverse at each end are bores with a slot and with a  $\varnothing$  30 mm.

1. Remove the lower nut from the sensor.
2. Put a sensor with assembled cable sidewise into the bore.
3. Attach the sensor with the flat side of detached nut from the lower side.  
Tighten with a suitable tool (wrench size 36), until a twisting safety of the sensor aligned to the north is given.

## III. MOUNTING INTO BORES

Material thickness for installation of the sensor between the nuts may be max. 10 mm.

1. Remove the lower thread nut from the sensor.
2. The sensor with cable-plug connection is led without cable into the bore and fastened by the opposite side with the loose nut as under I.3.
3. The loose nut to be touched now with the flat side first over the cable, in order to fasten the sensor as under I.3.

# Adjusting the wind vane to the north

For wind direction measurements the north mark on the sensor must be aligned with the geographical north direction. You have to turn the marking exactly over the marking at the sensor shaft. When you have aligned the marks, you may fix the wind vane with e.g. a piece of adhesive tape. When you have fixed the wind vane this way you can locate the reference point by aiming at it over the axis. Now you must turn the sensor casing on the mounting tube until the tip of the wind vane points to the reference point in the north.

To set up the sensor's north orientation select a landmark which is as far as possible up north with regard to the final position of the wind direction sensor. The reference point can be selected using a topographical map (1:25000). The exact position of the reference point is determined using an amplitude compass that can be adjusted horizontally on a stand.



**Be aware of compass misdirections.**

When the north direction is set up for the wind direction sensor, you can mounting it as under point "Principle of installation". Remove any adhesive tape.

If you cannot select a northern reference point owing to local conditions, you can proceed analogously using a reference point in the south. In this case, however, you have to make sure the north mark on the sensor does not point to the reference point but in the opposite direction.

## Electrical connections

PROFESSIONAL sensors are connected to a data measuring system via the open cable end (see example "Cable run"). The connecting cable is suitably led along the mast between the data evaluation device (indicating instrument or data acquisition system) and the sensor. The cable must be fastened using appropriate cable ties (their length depends on the mast diameter).

Route the cable from the pole to the base of the sensor housing via a generously sized bend to allow for easy disassembly as well as a water trap.



Please make sure the cable is protected from humidity on the side of the data processing system. Generally, Pg sockets that use a rubber joint to prevent humidity from penetrating into the terminal box of the data processing system provide sufficient protection.



Example: Cable run through an EMC-compliant Pg socket

Alternatively the lead can be laid also completely in the pipes of a mast, if the mast is accordingly prepared.



**To reduce the risk of inductive interference the sensor must be properly grounded (screening on both sides).**

## Heating

The sensor has an electronically controlled 18 watt heater in the sensor head. The heater is supplied together with the sensor electronics. (Separate supply of the sensor electronics and the heater with a permanently connected cable is possible on request).

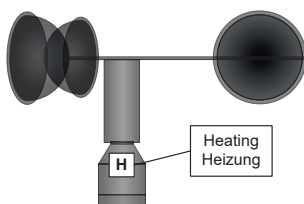

Under most climatological conditions the heating prevents blocking of the moving sensor parts (see illustration). The cup rotor or the wind vane are not heated. In case of icing or formation of ice at the moving sensor element the function is restricted for the period of icing.



## Maintenance

The sensor design permits long periods of maintenance-free operation. We therefore recommend a regular visual verification and functional test of the wind sensors as well as a sensor calibration of both sensor types at intervals of two years. With problems, which you cannot solve, do not hesitate to contact our LAMBRECHT service under:

Tel: +49-(0)551-4958-0

E-Mail: support@lambrecht.net

## Disposal

LAMBRECHT meteo GmbH is listed and registered at the Stiftung Elektro-Altgeräte Register ear under:

**WEEE-Reg.-Nr. DE 45445814**

In the category of monitoring and control instruments, device type: "Monitoring and control instruments for exclusively commercial use".

### Within the EU



The device has to be disposed according to the European Directives 2002/96/EC and 2003/108/EC (Waste Electrical and Electronic Equipment). Do not dispose the old device in the household waste! For an environmentally friendly recycling and disposal of your old device, contact a certified disposal company for electronic waste.

### Outside the EU

Please follow the regulations in your country regarding the appropriate disposal of waste electronic equipment.

## Technical data - Cable

ID 32.14567.060000 - Sensor cable with plug connection, length: 12 m

Flame resistance of the cable: acc. to UL Style 20549

### DIMENSIONED DRAWING

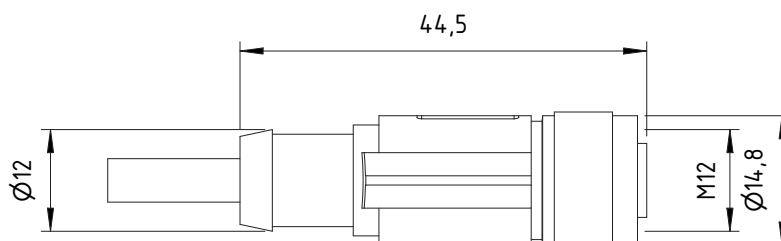



# Electrical connection

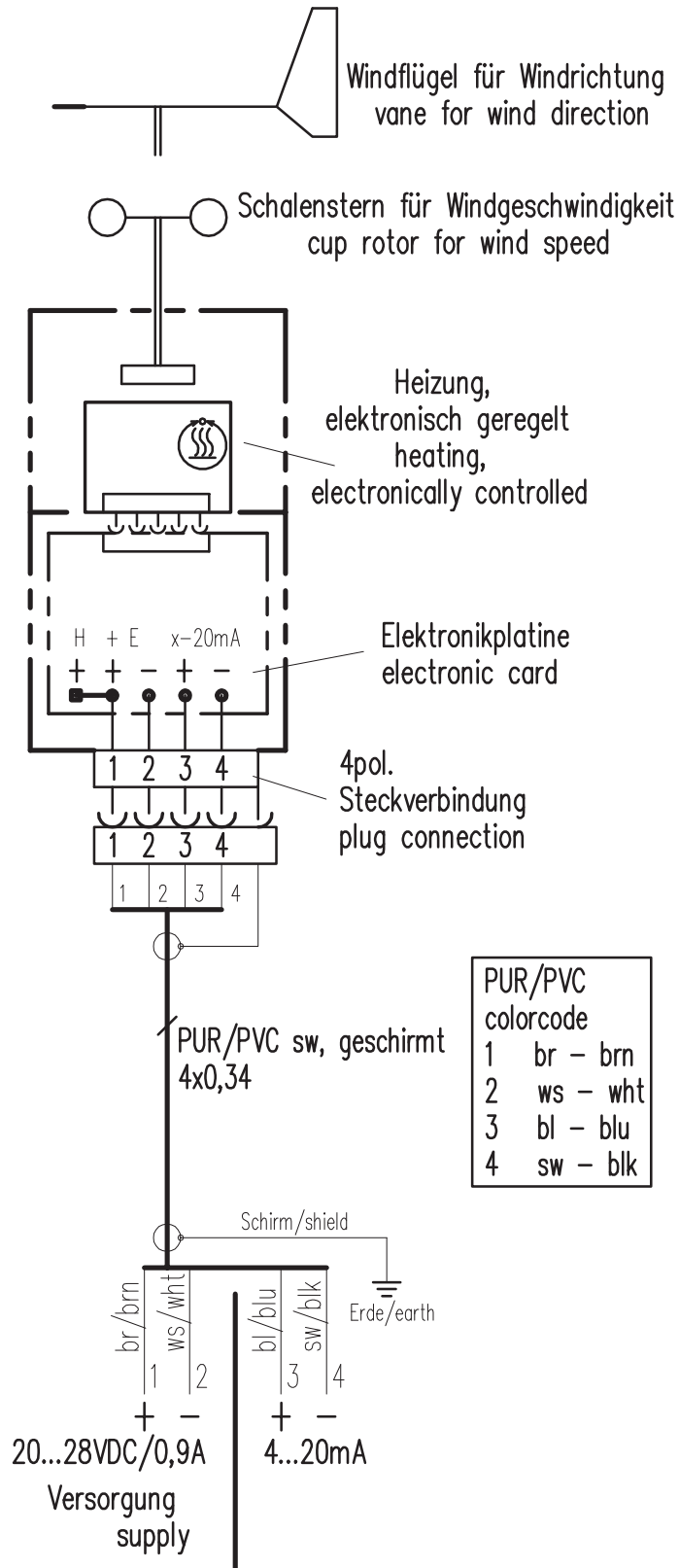

## Technical data - Sensors

	PROFESSIONAL Wind Direction	PROFESSIONAL Wind Speed
ID	00.14521.110040	00.14522.110040
<b>GENERAL</b>		
Measuring principle	Magnetical positioning encoder system (MPES)	
Range of application	temperature -40...+70 °C heated*; wind speed max. gusts 100 m/s	
Heating	18 W heating; electronically controlled. The heating within the sensor head prevents blocking of the moving parts under most climatological conditions.	
Supply voltage	24 VDC (20...28 VDC); maximal 800 mA	
Update rate	4 Hz	
Housing	seawater resistant aluminum; specially coated; black; IP65 in vertical position of use	
Dimensions	see dimensional drawings	
Scope of delivery	sensor; user manual	
PARAMETER	PROFESSIONAL Wind Direction	PROFESSIONAL Wind Speed
Measuring element	wind vane, dimensionally stable; Aluminum specially coated	three-armed cup rotor; Aluminum specially coated
Measuring range	0...360°	0.3...75 m/s
Accuracy	±1°	± 0.3 m/s ≤ 10 m/s; ± 1% FS ...50 m/s
Resolution	< 1°	< 0.1 m/s
Starting value	< 0,3 m/s	< 0.3 m/s
Output	4...20 mA = 0...360°	4...20 mA = 0...75 m/s
Damping ratio	0.5...0.6	---
Distant constant	---	4 m
Weight	0.4 kg	0.35 kg
<b>ACCESSORIES (please order separately)</b>		
ID 32.14567.060000	Sensor cable with plug connection, length: 12 m	
ID 32.14627.010000	Traverse; sensor distance: 75 cm	
ID 32.14567.006000	Mast adapter; diameter: 50 mm	
ID 32.14565.019000	Lightning rod	



\*) In case of possible icing and ice formation on the movable sensor measuring element, the function is reduced for the time of icing.