



USER MANUAL

# THP[pro]

Temperature-Humidity-Pressure Sensor



## Contents

1.	Safety instructions	3
2.	Warranty	3
3.	Key features	4
4.	Function	4
5.	Start-up	4
6.	Mounting	4
7.	Electrical connection	5
8.	Wiring diagram	5
9.	Dimensioned drawing	6
10.	Mounting of the sensor into the sensor shelter	7
11.	Perform measurements	8
11.1.	General on measurements	8
11.2.	LED codes	8
12.	General sources of error	8
13.	THP Connect - Configuration Tool	9
14.	Modbus protocol	10
14.1.	Wiring diagram Modbus	10
14.2.	General on Modbus	11
14.3.	Data encoding	11
14.4.	Standard configuration - Default	11
14.5.	Modbus commands	12
14.6.	Instantaneous values/realtime values (Input Register)	12
14.7.	Period data - average, maximum and minimum (Input Register)	12
14.8.	Descriptive sensor parameter registers (Holding Register)	13
14.9.	Sensor parameters / Configurations parameters	14
14.10.	Modbus tool	14
15.	SDI-12 Interface	15
15.1.	Wiring diagram SDI-12	15
15.2.	General on SDI-12	16
15.3.	Implemented SDI-12 commands	16
16.	NMEA protocol	26
16.1.	Wiring diagram NMEA	26
16.2.	Data protocols NMEA	26
17.	Maintenance and service	27
18.	Upkeep and care	28
19.	Download firmware and update	29
20.	Disposal	30
21.	Technical data	31



# 1. Safety instructions

This system is designed according to the state-of-the-art accepted safety regulations. However, please note the following rules:

- Before putting into operation please read all respective manuals!
- Please observe all internal and state-specific guidelines and/or rules for the prevention of accidents. If necessary ask your responsible safety representative.
- Use the system only as described in the manual.
- Always have the manual at hand at the installation site.
- Use the system within the specified operating condition. Eliminate influences, which might impair the safety.
- Prevent the ingress of unwanted liquids into the devices.
- Before cleaning, disconnect the system components from the power supply. Do not use health-hazardous or flammable cleaning agents

# 2. Warranty

**Please note the loss of warranty and non-liability by unauthorized manipulation of the system. You need a written permission of the LAMBRECHT meteo GmbH for changes of system components. These activities must be operated by a qualified technician.**

The warranty does not cover:

1. Mechanical damages caused by external impacts (e. g. icefall, rockfall, vandalism).
2. Impacts or damages caused by over-voltages or electromagnetic fields which are beyond the standards and specifications in the technical data.
3. Damages caused by improper handling, e. g. by wrong tools, incorrect installation, incorrect electrical installation (false polarity) etc.
4. Damages which are caused by using the device beyond the specified operation conditions.

## 3. Key features

- Three parameters in one sensor for maximum versatility and optimum efficiency
- Precision as per WMO and ICAO standards: Reliable measurements, globally recognized
- Low energy requirement - perfect for low-power applications
- Fail-safe and redundant pressure measuring with three independent ICs
- Easy configuration with USB-C interface right on the sensor
- Increased operational reliability of the sensor due to integrated LED status light

## 4. Function

### PROVEN ENVIRONMENTAL MEASUREMENT TECHNOLOGY

The sensor THP[pro] is a combined measuring instrument for measuring relative humidity, air temperature, and air pressure. The sensor is characterized by high reliability and energy-saving electronics. If the device is handled properly the perfect function and long-term stability as well as high accuracy are ensured.

## 5. Start-up

For climatic measurements the sensor should be mounted at a representative place. The sensor can be installed in any position. The sensor must be protected against water splashes and rain. As a suitable weather and protection screen we recommend the sensor shelter 8141.6.

Dew formation and splashes do not damage the sensor, although corrupted measurement readings are recorded until all the moisture on the sinter filter has dried up. Inside a room you should avoid a place near heatings, windows, and cold outer walls.



The sinter filter should only be removed when cleaning is necessary or when the sensor needs to be checked with a wet standard. Care should be taken to ensure that the highly sensitive sensor element is not touched.

When you screw them back on, please bear in mind that sensors will not measure accurately again until they are completely dry.

## 6. Mounting

First of all the protective screen has to be mounted without the incorporated sensor at a selected installation place as mentioned before. When having inserted the sensor THP[pro] bottom-up into the big support of sensor shelter 8141.6, the plastic nut must be fastened carefully with a wrench.



## 7. Electrical connection



**Incorrect voltage supplies and overloading of the outputs can destroy the sensor!**

The sensor THP[pro] has to be connected with the end of the cable to an external power supply and signal evaluation (see figure).

## 8. Wiring diagram

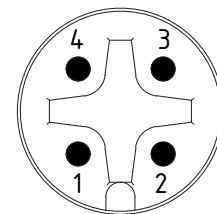
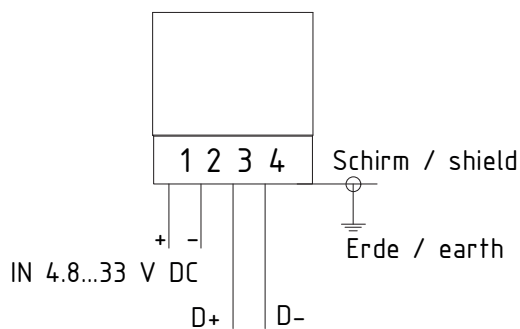

Ansicht Stiftseite  
View male side

Konf.	D+	D-
NMEA/ RS422	Tx +	Tx -
Modbus RTU / RS485	D+	D-
SDI-12	Data +	Data GND

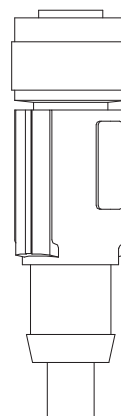

**Kabel / cable**  
32.14567.060010 (15 m)  
32.14567.060000 (12 m)

PIN	Color	Farbe
1	br	br
2	wt	ws
3	bl	bl
4	bk	sw

## 9. Dimensioned drawing

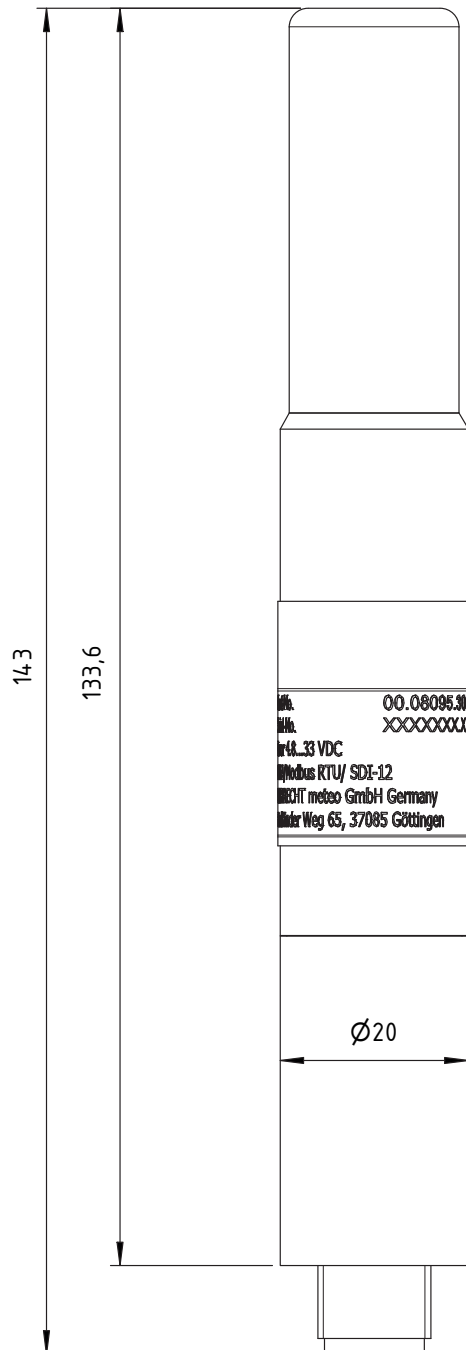

## 10. Mounting of the sensor into the sensor shelter

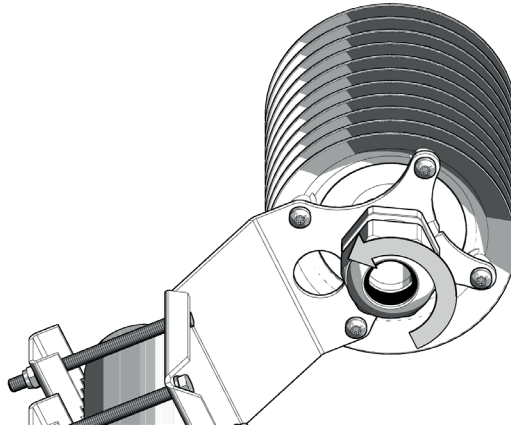

1

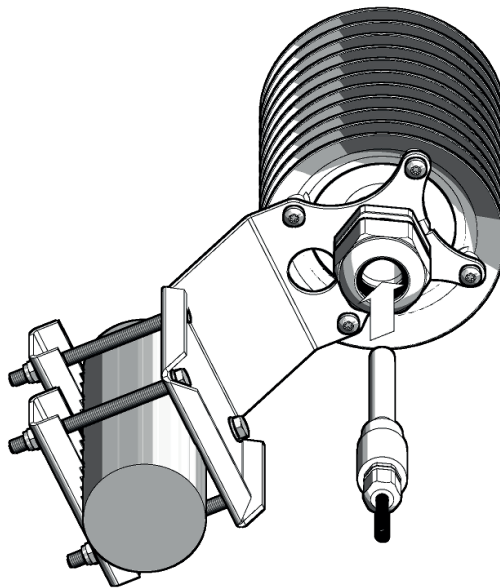

2

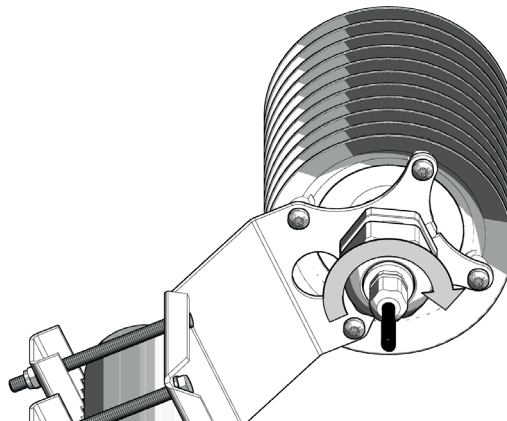

3

## 11. Perform measurements

### 11.1. General on measurements

The measuring probe is adjusted by delivery. For putting into operating another readjustment is not required. The probe is ready for use five seconds after being switched on and sends its first data protocol.



**Before a reliable measurement can be made, the measuring probe and medium to be measured must be in temperature and humidity equilibrium.**

The necessary adjustment time, which can last up to 30 minutes, depends upon several factors:

- Size of the humidity and temperature deviation of probe and medium before start of measurement
- Change of the measured values during the adjustment time

The humidity measurement provides a better picture of the progress of acclimatization since it reacts much more quickly and more sensitively than the temperature measurement. The 1/10 percent display is therefore very suitable as a trend display. If the display oscillates about mean value, then adjustment is completed.

### 11.2. LED codes

Shortly after the sensor is connected to the power supply, it indicates its status with an LED, which is visible through the sinter filter of the THP[pro]. The sinter filter does not need to be opened for this. The LED signals that the sensor is powered and simultaneously shows its status as well as which protocol has been set. The following table lists the respective status codes.

Description	LED code
Initialization after restart	Green (off after 3 seconds)
Initialization failure after restart	Red
NMEA activated (after restart or configuration)	Green, flashing once
Modbus activated (after restart or configuration)	Green, flashing twice
SDI-12 Legacy activated (after restart or configuration)	Green, flashing three times
SDI-12 activated (after restart or configuration)	Green, flashing four times
USB connected	Green

## 12. General sources of error

Humidity measurements are very sensitive to various influences:

### TEMPERATURE ERROR

Due to too short adjustment time, sunshine during the measurement, heating, cold outer wall, air draft (e.g. fans), radiating hand, and/or body heat etc..



## HUMIDITY ERROR

Due to steam, water splashes dripping water or condensation on the sensor etc.. Repeatability and long-term stability in operation are not impaired by this even if the probe has been exposed to high humidity or saturation with water vapor over a lengthy period.

## STAINING

Staining of the humidity sensor can be largely avoided by using a corresponding sinter filter. The sinter filters must be cleaned or replaced periodically depending upon the degree of contamination of the measuring site.



**The sensor is insensitive to chemicals, when they occur in normal concentrations (MAK values = maximum workplace exposure). At higher concentrations or possibilities of contact with liquid chemicals, the manufacturer must always be consulted!**

## 13. THP Connect – Configuration Tool

The configuration of the THP[pro] can be easily changed using the THP Connect configuration tool. THP Connect is a Windows application that is compatible with Windows 7 and later.

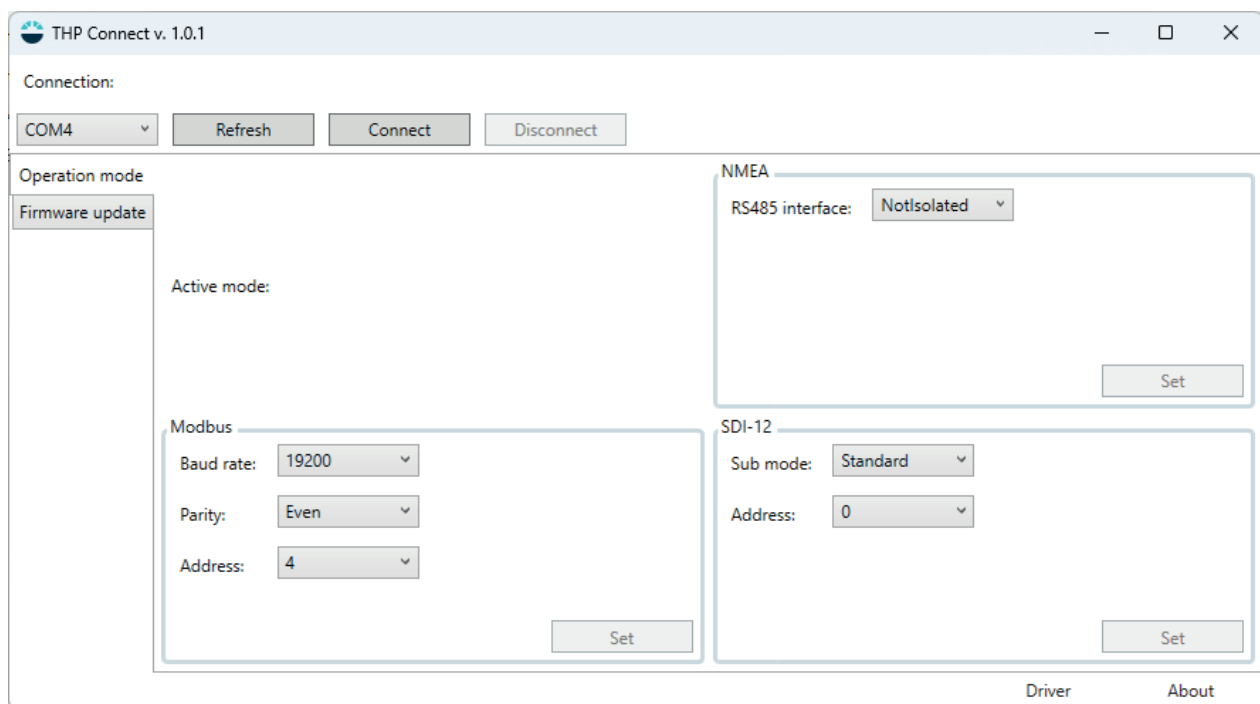

With THP Connect, the output protocol can be configured:

- **NMEA**
  - Not Isolated RS-485
  - Isolated RS-485

- **Modbus**
  - Device address
  - Baud rate
  - Parity
- **SDI-12**
  - SDI-12 Sub Mode
    - SDI-12 Legacy
    - SDI-12 Standard
  - SDI-12 Device address
- For configuration, the THP[pro] only needs to be connected to a PC running THP[pro] Connect via USB-C. The THP[pro] is powered through the USB interface; no additional power supply or interface converter is required.
- As soon as the sensor has been connected via USB, the status LED lights up green permanently.
- Under "Connection", the appropriate COM port must now be selected, and the Connect button must be pressed.
- The currently set protocol is now displayed under "Active mode:", and the corresponding configuration field is marked in RED.
- By pressing the "Set" button, the respective protocol can be activated. If the THP[pro] accepts the selection, the new configuration field will be marked in RED.
- Once the configuration has been completed, the connection to the THP[pro] can be terminated properly by pressing the "Disconnect" button.

## 14. Modbus protocol

### 14.1. Wiring diagram Modbus

Modbus RTU RS485

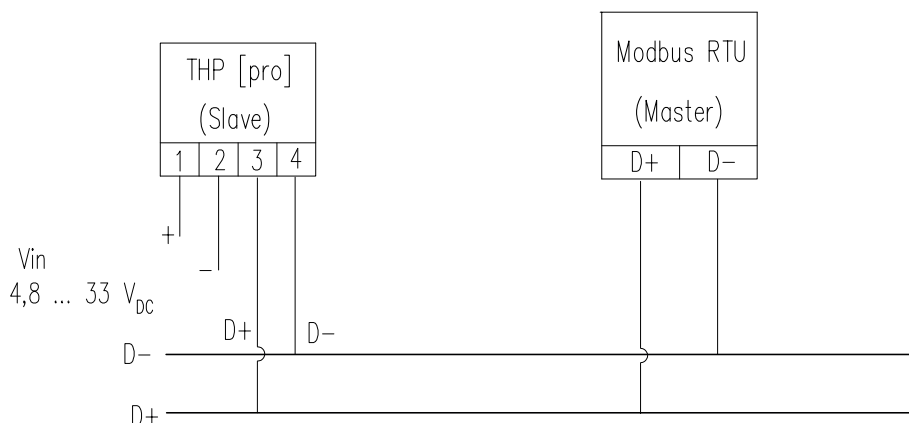

## 14.2. General on Modbus

The LAMBRECHT meteo Modbus sensors follow the specification of the Modbus organization: "MODBUS APPLICATION PROTOCOL SPECIFICATION V1.1b3" (see [www.modbus.org](http://www.modbus.org)).

## 14.3. Data encoding

MODBUS uses the "Big-Endian" format for addresses and data. This means that if a value is transmitted with a number format which is larger than a single byte, that the "most significant byte" is sent first.

### Example Big-Endian:

Register size value

16 - bits 0x1234 is transmitted in the sequence: 0x12 0x34

To obtain the real measuring value, divide the received register value by the divisor.

Values of -9999 indicate an internal sensor error.

## 14.4. Standard configuration - Default

Baud rate: 19200 Baud

Byte frame: 8E1 (1 start bit, 8 data bits, 1 parity bit (even parity), 1 stop bit)

RTU Sensor address: 4

### DEFAULT ADDRESSES OF THE LAMBRECHT SENSORS

Address	Sensor
1	Wind speed
2	Wind direction
3	Precipitation rain[e]
4	THP[pro]
5	EOLOS IND; u[sonic]WS6
6	com[b]
7	PREOS
8	ARCO
9	u[sonic]
10	Pyranometer 2nd Class
11	Secondary standard Pyranometer
12	PT100 to Modbus converter (temperature)
13	u[sonic]WS7

## 14.5. Modbus commands

- "Read Holding Register" command: 0x03 (descriptive sensor data registers)
- "Read Input Register" command: 0x04 (every measured value is to be requested individually)
- "Write Multiple Register" command: 0x10 (write to configuration registers)

## 14.6. Instantaneous values/realtime values (Input Register)

Register	Parameter name	Unit	Divisor	Quantity of registers	Access type
30401	Air temperature	°C	10	1	Read only
30601	Relative humidity	% r. h.	10	1	Read only
30701	Dew point	°C	10	1	Read only
30801	Air pressure	hPa	10	1	Read only
33560	Absolute humidity	g/m <sup>3</sup>	10	1	Read only
33541	Wet-bulb temperature	°C	10	1	Read only

**Example:** Retrieving air temperature

04	04	76	C1	00	01	7A	2B	04	04	02	00	E1	B5	7B
----	----	----	----	----	----	----	----	----	----	----	----	----	----	----

LEN 6	Transmission Query =>	Source Master	Dest Slave 4	Function Read Input Register (4)	Func Desk Address=30401, Quantity of Register=1	Checksum OK:2B7A
----------	--------------------------	------------------	-----------------	-------------------------------------	--	---------------------

LEN 5	Transmission Response <=	Source Slave 4	Dest Master	Function Read Input Register (4)	Func Desk Byte count=2	Data 00 E1	Checksum OK:7BB5
----------	-----------------------------	-------------------	----------------	-------------------------------------	---------------------------	---------------	---------------------

## 14.7. Period data - average, maximum and minimum (Input Register)

Register	Parameter name	Unit	Divisor	Quantity of registers	Access type
30402	Air temperature average	°C	10	1	Read only
30403	Air temperature maximum	°C	10	1	Read only
30404	Air temperature minimum	°C	10	1	Read only
30602	Relative humidity average	% r.h.	10	1	Read only
30603	Relative humidity maximum	% r.h.	10	1	Read only
30604	Relative humidity minimum	% r.h.	10	1	Read only
30702	Dew point average	°C	10	1	Read only
30703	Dew point maximum	°C	10	1	Read only
30704	Dew point minimum	°C	10	1	Read only
30802	Air pressure average	hPa	10	1	Read only
30803	Air pressure maximum	hPa	10	1	Read only
30804	Air pressure minimum	hPa	10	1	Read only
33561	Absolute humidity average	W/m <sup>2</sup>	10	1	Read only
33562	Absolute humidity maximum	W/m <sup>2</sup>	10	1	Read only
33563	Absolute humidity minimum	W/m <sup>2</sup>	10	1	Read only

33542	Wet-bulb temperature average	°C	10	1	Read only
33543	Wet-bulb temperature maximum	°C	10	1	Read only
33544	Wet-bulb temperature minimum	°C	10	1	Read only

The data are valid for the period between the current request and the previous request. The maximum range of a period is 1 hour. Recalling the average value of a minimum, maximum and average group will erase the appropriate registers.

Retrieve the values of a group in the sequence minimum, maximum, average.

Use command: 0x03

**Example:** Retrieving air temperature (min. max. avr.) and deleting the register content

04	04	76	C4	00	01	6A	2A	04	04	02	00	D8	75	6A	04
04	76	C3	00	01	DB	EB	04	04	02	00	E2	F5	79	04	04
76	C2	00	01	8A	2B	04	04	02	00	E2	F5	79			

LEN 6	Transmission Query =>	Source Master	Dest Slave 4	Function Read Input Register (4)	Func Desk Address=30404, Quantity of Register=1	Checksum OK:2A6A
LEN 5	Transmission Response <=	Source Slave 4	Dest Master	Function Read Input Register (4)	Func Desk Byte count=2	Data 00 D8 Checksum OK:6A75
LEN 6	Transmission Query =>	Source Master	Dest Slave 4	Function Read Input Register (4)	Func Desk Address=30403, Quantity of Register=1	Checksum OK:EBDB
LEN 5	Transmission Response <=	Source Slave 4	Dest Master	Function Read Input Register (4)	Func Desk Byte count=2	Data 00 E2 Checksum OK:79F5
LEN 6	Transmission Query =>	Source Master	Dest Slave 4	Function Read Input Register (4)	Func Desk Address=30402, Quantity of Register=1	Checksum OK:2B8A
LEN 5	Transmission Response <=	Source Slave 4	Dest Master	Function Read Input Register (4)	Func Desk Byte count=2	Data 00 E2 Checksum OK:79F5

## 14.8. Descriptive sensor parameter registers (Holding Register)

Register	Parameter name	Quantity of registers	Remark	Access type
40050	Device identification number (15 characters)	8 (2 characters in each register)	The returned data are in form of a 16 byte null terminated string	Read only
40100	Serial number (11 characters)	6 (2 characters in each register)	The returned data are in form of a 12 byte null terminated string	Read only
40150	Firmware version (up to 25 characters)	13 (2 characters in each register)	The returned data are in form of a 26 byte null terminated string	Read only

**Example:** Retrieving the device identification number (The identification number shown in the example is sensor-dependent. It is used here for demonstration purposes only).

05	03	9C	72	00	08	CB	C3	05	03	10	30	30	2E	31	36	□□□□□□□□□□□□□□
34	38	30	2E	30	30	30	31	33	30	00	37	CA				00.16480.000130□□□□
LEN 6	Transmission Query =>	Source Master	Dest Slave 5	Function Read Holding Register (3)	Func Desk Address=40050, Quantity of Register=8	Checksum OK:C3CB										
LEN 19	Transmission Response <=	Source Slave 5	Dest Master	Function Read Holding Register (3)	Func Desk Byte count=16	Data 30 30 2E 31 36 34 38 30 2E 30 30 30 31 33 30 00	Checksum OK:CA37									

### 14.9. Sensor parameters / Configurations parameters

Register	Parameter name	Permissible values	Quantity of registers	Access type
40001	Modbus address device		1	Write only
40200	Baud rate	96 = 9600 192 = 19200 384 = 38400	1	Write only
40201	Parity	1 = even 0 = none	1	Write only

The device must be restarted after each change of a setting!

**Example:** Changing the RTU address from 13 to 1

05	10	9C	41	00	01	02	00	01	06	48	05	10	9C	41	00	01	7E	09
LEN 9	Transmission Query =>	Source Master	Dest Slave 5	Function Write Multiple Register (16)	Func Desk Address=40001, Quantity=1	Byte count 2	Register values 00 01	Checksum OK:4806										
LEN 6	Transmission Response <=	Source Slave 5	Dest Master	Function Write Multiple Register (16)	Func Desk Address=40001, Quantity=1	Checksum OK:097E												

### 14.10. Modbus tool

On our website (<https://www.lambrecht.net>), the **Free Software Tools & Firmware** category can be found under **Service** in the **Resources** section. There you can easily download the latest firmware and the configuration software "THP Connect" for your product and benefit from ongoing improvements and new features.

The application "Modbus\_Tool" is used for checking, verifying the function and configuration of LAMBRECHT meteo Modbus sensors.

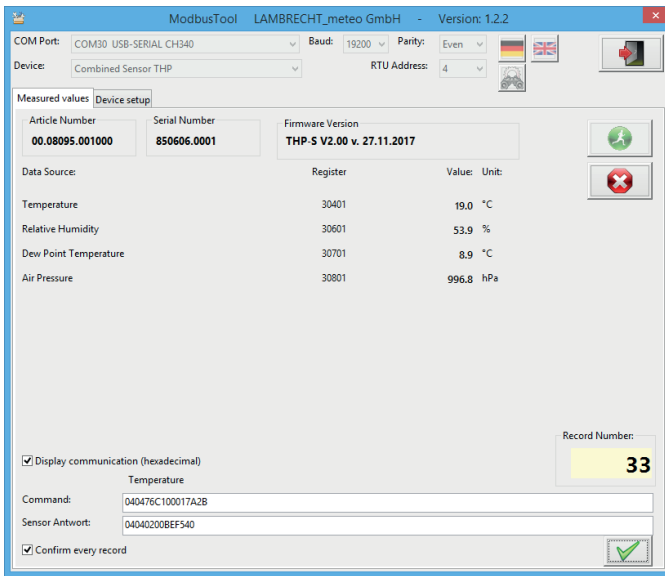

In the "Measured values" section, property data (article number, serial number and firmware version) and measured values are retrieved and displayed. In addition, the communication history can be displayed in hexadecimal format.

In the "Settings" area, the baud rate, parity, and RTU address can be adapted to the user's requirements.

## 15. SDI-12 Interface

### 15.1. Wiring diagram SDI-12

SDI-12

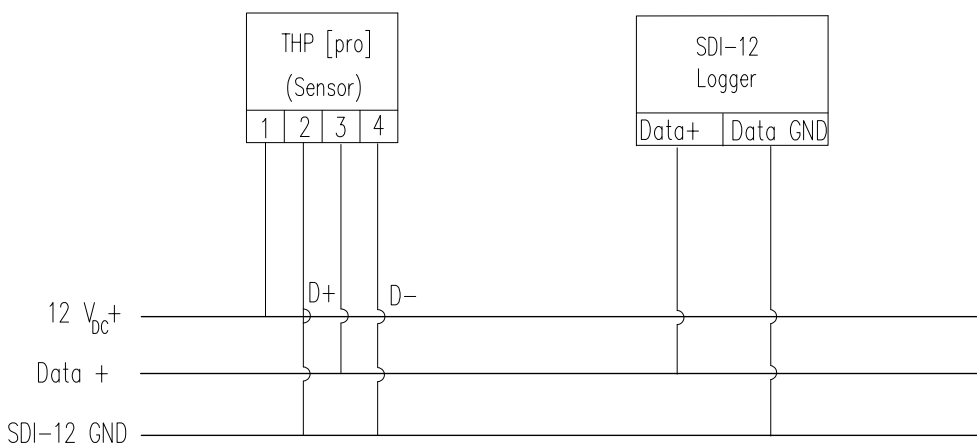

## 15.2. General on SDI-12

Communication using the SDI-12 protocol over the SDI-12 interface is based on the "SDI-12 A Serial Digital Interface Standard for Microprocessor-Based Sensors, Version 1.3, 2016." The THP[pro] sensor can be used in a bus configuration alongside other sensors that utilize the SDI-12 data protocol.

The THP[pro] sensor supports two different SDI-12 modes, which can be configured using the THP Connect tool:

- SDI-12 Legacy
- SDI-12 Standard

The SDI-12 Legacy mode is fully compatible with previous versions and allows for seamless sensor interchangeability. In this mode, the sensor performs continuous measurements and does not enter a "sleep mode." Since measurements are taken continuously, in addition to the instantaneous value, additional values for the minimum, maximum, and average of the respective parameter can be provided. However, this results in increased power consumption of the sensor.

In the SDI-12 Standard mode, continuous measurement does not occur, and the sensor enters a "sleep mode" until an SDI-12 break is sent. Therefore, only instantaneous values are available in this mode, which also affects the structure of the sensor's response to the SDI-12 command **aD0!**. The commands **aD1!** and **aD2!** are non-functional in the SDI-12 Standard mode. This mode has the lowest power consumption, making it recommended for low-power applications.

The following subset of SDI-12 commands is implemented in the THP[pro] sensor. For more information on the SDI-12 protocol, please refer to the aforementioned standard documentation or visit the website [www.SDI-12.org](http://www.SDI-12.org).

## 15.3. Implemented SDI-12 commands

Command	Function	Sensors response
a!	Acknowledge active	a<CR><LF>
?!	Address query	a<CR><LF>
al!	Send identification	alccccccmmmmmmvvvxx...xx<CR><LF>
aAb!	Change address	b<CR><LF>
aM!	Start measurement	atttn<CR><LF>
aMC!	Start measurement and request CRC	atttn<CR><LF>
aC!	Start concurrent measurement	atttn<CR><LF>
aCC!	Start concurrent measurement and request CRC	atttn<CR><LF>
aD0!	Send data (buffer 0)	a<Werte><CR><LF>
aD1!	Send data (buffer 1)	a<Werte><CRC><CR><LF>
aD2!	Send data (buffer 1)	
aV!	Start verification	atttn<CR><LF>

a = address of the corresponding sensor; standard sensor address = 0

SDI-12 commands always start with the address of the corresponding sensor. Thus all other sensors on the same

bus ignore commands that do not match their own address. SDI-12 commands end with a "! All sensor responses also start with the address (shown below with "a") of the sensor and always end with the ASCII characters "Carriage Return" "<CR>" and "Line Feed" "<LF>".

The SDI-12 protocol is based on the ASCII character set. The baud rate is 1200 Baud and has the byte frame format:

1 start bit  
7 data bits (least significant bit first)  
1 parity bit (even parity)  
1 stop bit

### Acknowledge active – (a!)

This command ensures that the sensor responds to requests. In general, it requests the sensor to confirm that it is connected to the bus. The sensor returns its address and the characters <CR><LF>.

Command: **a!** (Acknowledge active)

Response: **a<CR><LF>**

Example:	Command	Response
	<b>0!</b>	<b>0&lt;CR&gt;&lt;LF&gt;</b>
	<b>1!</b>	<b>1&lt;CR&gt;&lt;LF&gt;</b>

### Send identification – (a!)

Output of sensor-specific information, such as model number, and firmware version.

Command: **a!** (I – Command "Send Identification")

Antwort: **a13LMGmbH1508095x310871202.0001<CR><LF>**

			<b>871202.0001</b> – (11 characters) serial number TH/THP
			<b>310</b> – (3 characters) sensor firmware version (= version 3.10)
			<b>08095x</b> – (6 characters) sensor type (x: T = TH[pro], P = THP[pro])
			<b>LMGmbH15</b> – (8 characters) manufacturer name (= Lambrecht meteo GmbH)
			<b>13</b> – (2 characters) SDI-12 - version (13 = version 1.3)

Example:	Command	Response
	<b>0!</b>	<b>013LMGmbH1508095T310871202.0001&lt;CR&gt;&lt;LF&gt;</b> (TH[pro])
	<b>1!</b>	<b>113LMGmbH1508095P310871202.0001&lt;CR&gt;&lt;LF&gt;</b> (THP[pro])

## Change address – (aAb!)

The factory setting for the address is **0**. If several sensors are connected to the same bus, the sensor address can be changed with the command **aAb!**. The address is always a single ASCII character. By default, the ASCII characters are used for the numbers between **0** to **9** (decimal 48 to 57). If more than 10 sensors are connected to one bus, the characters **A** to **Z** (decimal 65 to 90) as well as **a** to **z** (decimal 97 to 122) can be used alternatively. The sensor responds with its new address and **<CR><LF>**. After the address has been changed, no further commands should be sent to the sensor for about one second (see also "SDI-12 Standard, Version 1.3, 2016").

Command:      **aAb!**                              **A** – command "change address", **b** – new sensor address  
 Response:     **b<CR><LF>**                      **b** – response with new sensor address

**Example:**        Command                      Response  
                   **0A!**                              **1<CR><LF>**

## Start measurement – (aM!) SDI-12 Legacy

The command **aM!** requests the sensor to process the available measurement data and to record it in an output string. Unlike the standard sensors as described in the SDI-12 documentation, the THP[pro] sensor measures continuously. The data can be retrieved with the corresponding commands **aD0!** to **aD2!**. The data is saved until the next **C**, **M**, or **V** command and can be retrieved several times.

Command:      **aM!**                              **M** – command "start measurement"  
 Response:     **a0005<CR><LF>**  
                   |    |  
                   |    **5** – number of measured values  
                   **000** – seconds until the sensor returns the measured data (000 = immediate query possible)

**Example:**        Command                      Response  
                   **1M!**                              **10005<CR><LF>**

The measurement data can then be retrieved with the commands **aD0!**, **aD1!**, and **aD2!** (see under "Send data").

## Start measurement – (aM!) SDI-12 Standard

The **aM!** command requests the sensor to start a measurement.

The measuring data can be retrieved with the **aD0!** command.

Command:      **aM!**                              **M** – command "start measurement"

Response: **a0013<CR><LF>**  
 | |  
 | **3** – number of measured values  
**001** – seconds until the sensor returns the measured data

The measurement data can then be retrieved with the command **aD0!** (see under "Send data").

### Start measurement and request CRC – (aMC!) SDI-12 Legacy

Same command as **aM!**, but in addition to the processed measurement data, the sensor sends a 3-digit CRC checksum. For further information on generating this CRC checksum please refer to "SDI-12 Standard, Version 1.3, 2016, Chapter 4.4.12".

Command: **aMC!** **M** – command "start measurement", **C** – request CRC checksum

Response: **a0005<CR><LF>**  
 | |  
 | **5** – number of measured values  
**000** – seconds until the sensor returns the measured data (000 = immediate query possible)

**Example:** Command Response  
**1MC!** **10005<CR><LF>**

### Start measurement and request CRC – (aMC!) SDI-12 Standard

The command **aMC!** requests the sensor to start a measurement and sends the measurement data along with a 3-digit CRC checksum.

The data can be retrieved using the corresponding commands **aD0!**.

Command: **aMC!** **MC** – command "start measurement" and request for a CRC checksum"

Response: **a0013<CR><LF>**  
 | |  
 | **3** – number of measured values  
**001** – seconds until the sensor returns the measured data

The measurement data can then be retrieved with the command **aD0!** (see under "Send data").

### Start concurrent measurement – (aC!) SDI-12 Legacy

With "concurrent measurement", the data logger can measure concurrently with several THP[pro] sensors connected to the same bus. The command **aC!** requests the sensor to process the available measurement data and record them in an output string. Unlike the standard sensors, as described in the SDI-12 documentation, the THP[pro] measures continuously. The data can be retrieved with the corresponding commands **aD0!** to **aD2!**. The data is saved until the next **C**, **M**, or **V** command and can be retrieved several times.

Command: **aC!** **C** – command "start concurrent measurement"

Response: **a00024<CR><LF>** (THP[pro])

| |

| **24** – number of measured values

**000** – seconds until the sensor returns the measured data (000 = immediate query possible)

<b>Example:</b>	Command	Response
	<b>1C!</b>	<b>100024&lt;CR&gt;&lt;LF&gt;</b>

The measurement data can then be retrieved with the commands **aD0!**, **aD1!**, and **aD2!** (see under "Send data").

### Start concurrent measurement – (aC!) SDI-12 Standard

In "concurrent measurement", the data logger can measure simultaneously with multiple THP[pro] sensors connected to the same bus. The command **aC!** requests the sensor to start a measurement and sends the measuring data along with a 3-digit CRC checksum.

The data can be retrieved using the command **aD0!**.

Command: **aC!** **C** – command "start concurrent measurement"

Response: **a00109<CR><LF>**

| |

| **09** – number of measured values

**001** – seconds until the sensor returns the measured data

The measurement data can then be retrieved with the command **aD0!** (see under "Send data").

### Start concurrent measurement and request CRC – (aCC!) SDI-12 Legacy

Same command as **aC!**, but in addition to the processed measurement data, the sensor also sends a 3-digit CRC checksum. For further information on generating this CRC checksum please refer to "SDI-12 Standard, Version 1.3, 2016, Chapter 4.4.12".

Command: **aCC!** **C** – command "start concurrent measurement", **C** – request CRC checksum

Response: **a00024<CR><LF>**

| |

| **24** – number of measured values

**000** – seconds until the sensor returns the measured data (000 = immediate query possible)

<b>Example:</b>	Command	Response
	<b>1C!</b>	<b>100024&lt;CR&gt;&lt;LF&gt;</b>

The measurement data can then be retrieved with the commands **aD0!**, **aD1!**, and **aD2!** (see under "Send data").



## Start concurrent measurement and request CRC – (aCC!) SDI-12 Standard

In "concurrent measurement", the data logger can measure simultaneously with multiple THP[pro] sensors connected to the same bus. The command **aCC!** requests the sensor to start a measurement and sends the measurement data along with a 3-digit CRC checksum.

The measurement data can then be retrieved with the command **aD0!** (see under "Send data").

Command:     **aCC!**                    **CC** – command "start concurrent measurement" and request for a CRC checksum

Response:    **a00109<CR><LF>**

| |

| **09** – number of measured values

**001** – seconds until the sensor returns the measured data

The measurement data can then be retrieved with the command **aD0!** (see under "Send data").

## Send data – (aD0!), (aD1!), (aD2!)

In SDI-12 Legacy mode, the data requested from the sensor using the commands **C** or **M** can be retrieved with the commands **aD0!**, **aD1!**, and **aD2!**.

In SDI-12 Standard mode, only the command **aD0!** is responded to, as fewer data are provided.

The sensor uses the appropriate signs ("+" or "-") as field delimiters. When the data is requested with a **CC** or **MC** command, a CRC checksum is also returned. For more information on generating this CRC checksum, please refer to "SDI-12 Standard, Version 1.3, 2016, Chapter 4.4.12." The measurement data is provided in metric units.

Up to a maximum of 20 measurement values can be distributed across the output telegrams **aD0!**, **aD1!**, and **aD2!** for retrieval in SDI-12 Legacy mode. The "from retrieval to retrieval" period is limited to a maximum of 70 minutes. After this period, the instantaneous as well as the min/max values are reset, and a new observation period is automatically initiated.

If erroneous data is generated during the measurement or if the sensor's function is permanently impaired, the corresponding measurement data will be output with the "sensor error value" of -999.9. This designation is unambiguous and lies well outside the actual measurement range.

### **Example (error codes):**

Command:     **1CC!** and following query of block 1 of the measured data with **1D0!**

Response:    1-999.9-999.9-999.9-999.9-999.9-999.9-999.9GGi<CR><LF>

**Data and retrieval description – THP[pro]** (24 measured values)

Value no.	Measured values	Range / Formats	Unit
<b>1</b>	<b>Air temperature</b> Instantaneous value	-40.0...+70.0	°C
2	Minimum (from retrieval to retrieval)		
3	Maximum (from retrieval to retrieval)		
4	Mean value (from retrieval to retrieval)		
<b>5</b>	<b>Relative humidity</b> Instantaneous value	+0.0...+100.0	%
6	Minimum (from retrieval to retrieval)		
7	Maximum (from retrieval to retrieval)		
8	Mean value (from retrieval to retrieval)		
<b>9</b>	<b>Dew point</b> Instantaneous value	-40.0...+70.0	°C
10	Minimum (from retrieval to retrieval)		
11	Maximum (from retrieval to retrieval)		
12	Mean value (from retrieval to retrieval)		
<b>13</b>	<b>Air pressure</b> Instantaneous value	+600.0...+1100.0	hPa
14	Minimum (from retrieval to retrieval)		
15	Maximum (from retrieval to retrieval)		
16	Mean value (from retrieval to retrieval)		
<b>17</b>	<b>Absolute humidity</b> Instantaneous value	+0.0...+200.0	g/m <sup>3</sup>
18	Minimum (from retrieval to retrieval)		
19	Maximum (from retrieval to retrieval)		
20	Mean value (from retrieval to retrieval)		
<b>21</b>	<b>Wet bulb temperature</b> Instantaneous value	-40.0...+70.0	°C
22	Minimum (from retrieval to retrieval)		
23	Maximum (from retrieval to retrieval)		
24	Mean value (from retrieval to retrieval)		

**THP[pro] SDI-12 Legacy – Output of measured data when queried with aM! or aMC! (with CRC checksum)**

Command: **aM!** (aM! = buffering instantaneous values for output)  
 Response: **10005<CR><LF>** (5 measured values are available for retrieval without delay)

Command: **aD0!** (retrieve measured values from buffer memory)

Response: **a+22.5+41.2+8.7+976.0+8.2<CR><LF>**  
 | | | | |  
 | | | | **+8.2** – absolute humidity (value no. 17)  
 | | | **+976.0** – air pressure (value no. 13)  
 | | **+8.7** – dew point (value no. 9)  
 | **+41.2** – relative humidity (value no. 5)  
**+22.5** – air temperature (value no. 1)

Command: **aD1!**

Response: **a+12.3<CR><LF>**  
 |  
**+12.3** – wet bulb temperature (value no. 21)

**Example:** Command Response  
**1MC!** **1+22.2+39.6+7.8+975.1+7.7KNJ<CR><LF>**

**THP[pro] SDI-12 Standard – Output of measured data when queried with aM! oder aMC! (with CRC checksum)**

Requesting measurement data by command **aM** or **aMC!** – (aD0!).

**aD0!a+23.2+54.8+985.3O\C<CR><LF>**  
 | | | | |  
 | | | | **O\C** – checksum (only for aMC!)  
 | | **+985.3** – air pressure, instantaneous value (value no. 13)  
 | **+54.8** – relative humidity, instantaneous value (value no. 5)  
**+23.2** – air temperature, instantaneous value (value no. 1)

**THP[pro] SDI-12-Legacy – Output of measured data when queried with aC! or aCC!  
(with CRC checksum)**

Command: **aC!** (aC! = buffering all available values for output)  
 Response: **100024<CR><LF>** (24 measured values are available for retrieval without delay)

**Note:** Due to the length limitation to max. 75 bytes, the data are split into 3 data sets!

Command: **aD0!** (aD0! = call up measured values 1 to 8 from **buffer memory 1**)

Response: **1+22.3+22.2+22.4+22.2+37.6+36.0+37.6+36.8<CR><LF>**  
 | | | | | | | |  
 | | | | | | | **+36.8** – relative humidity, mean value (value no. 8)  
 | | | | | | **+37.6** – relative humidity, maximum (value no. 7)  
 | | | | | **+36.0** – relative humidity, minimum (value no. 6)  
 | | | | **+37.6** – relative humidity, instantaneous value (value no. 5)  
 | | | **+22.2** – air temperature, mean value (value no. 4)  
 | | **+22.4** – air temperature, maximum (value no. 3)  
 | **+22.2** – air temperature, minimum (value no. 2)  
**+22.3** – air temperature, instantaneous value (value no. 1)

Command: **aD1!** (aD1! = call up measured values 9 to 16 from **buffer memory 2**)

Response: **1+7.2+6.5+7.2+6.8+978.5+978.4+978.8+978.5<CR><LF>**  
 | | | | | | | |  
 | | | | | | | **+978.5** – air pressure, mean value (value no. 16)  
 | | | | | | **+978.8** – air pressure, maximum (value no. 15)  
 | | | | | **+978.4** – air pressure, minimum (value no. 14)  
 | | | | **+978.5** – air pressure, instantaneous value (value no. 13)  
 | | | **+6.8** – dew point, mean value (value no. 12)  
 | | **+7.2** – dew point, maximum (value no. 11)  
 | **+6.5** – dew point, minimum (value no. 10)  
**+7.2** – dew point, instantaneous value (value no. 9)

Command: **aD2!** (aD2! = call up measured values 17 to 24 from **buffer memory 3**)

Response: **1+7.4+7.1+7.4+7.2+12.2+12.1+12.5+12.3<CR><LF>**  
 | | | | | | | |  
 | | | | | | | **+12.3** – wet bulb temperature, mean value (value no. 24)  
 | | | | | | **+12.5** – wet bulb temperature, maximum (value no. 23)  
 | | | | | **+12.1** – wet bulb temperature, minimum (value no. 22)  
 | | | | **+12.2** – wet bulb temperature, instantaneous value (value no. 21)  
 | | | **+7.2** – absolute humidity, mean value (value no. 20)  
 | | **+7.4** – absolute humidity, maximum (value no. 19)  
 | **+7.1** – absolute humidity, minimum (value no. 18)  
**+7.4** – absolute humidity, instantaneous value (value no. 17)

## THP[pro] SDI-12 Standard – Output of measured data when queried with aC! oder aCC! (with CRC checksum)

Requesting measurement data by command **aC** or **aCC!** - (aD0!).

**aD0!a+23.1+54.8+985.3+985.5+985.4+984.8+11.4+13.6+17.1@XT<CR><LF>**

									@XT - checksum (only for <b>aCC!</b> )
									+17.1 - wet bulb temperature, instantaneous value (value no. 21)
									+13.6 - dew point, instantaneous value (value no. 9)
									+11.4 - absolute humidity, instantaneous value (value no. 17)
									+984.8 - air pressure, sensor 3 instantaneous value (value no. 13.3)
									+985.4 - air pressure, sensor 2 instantaneous value (value no. 13.2)
									+985.5 - air pressure, sensor 1 instantaneous value (value no. 13.1)
									+985.3 - air pressure, instantaneous value (value no. 13)
									+54.8 - relative humidity, instantaneous value (value no. 5)
									+23.1 - air temperature, instantaneous value (value no. 1)

## Start verification – (aV!)

For compatibility reasons, the command **aV!** is used to provide extended information if necessary later. The response is always "1".

Command: **aV!** (Acknowledge Active)

Response: **a<CR><LF>**

<b>Example:</b>	Command	Response
	<b>1V!</b>	<b>1+1&lt;CR&gt;&lt;LF&gt;</b>

## Note on SDI standard commands

In terms of protocol, THP[pro] support the standard command set (see "SDI-12 A Serial-Digital Interface Standard for Microprocessor-Based Sensors, version 1.3, 2016", page 7, chapter 4.4 and table 5).

The sensors respond to all commands with a valid data transfer. The information content of unsupported commands is reduced to pure protocol sequence control, i.e. there is no further activity for these requests (e.g. **aD3!** etc.) due to the responses sent.

## 16. NMEA protocol

### 16.1. Wiring diagram NMEA

NMEA RS422

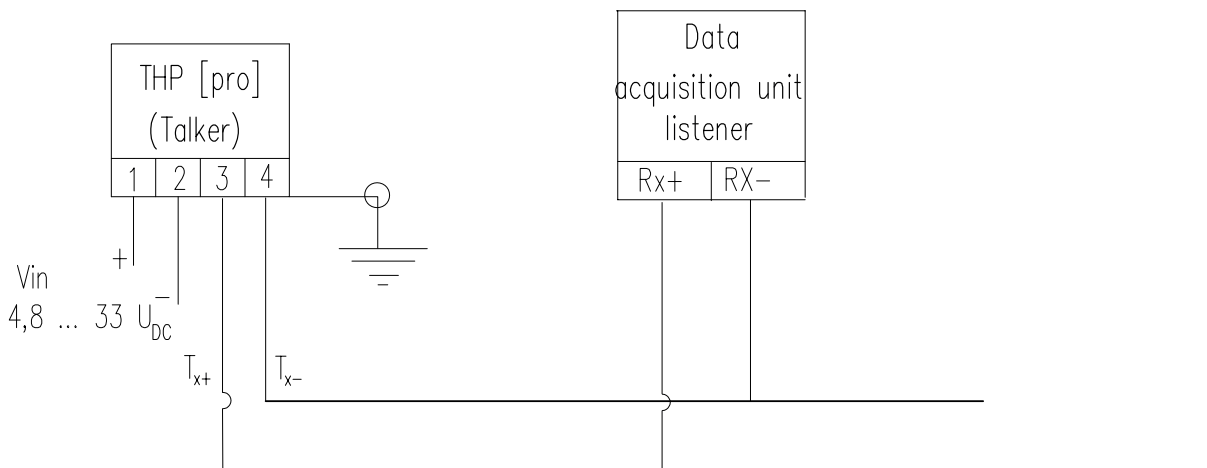

### 16.2. Data protocols NMEA

#### MESSAGE STRING WIMTA AIR TEMPERATURE

Example of data sequence with comma separated fields: \$WIMTA,-25.0,C\*CS<CR><LF>  
 field delimiter: , (comma)  
 header: \$WIMTA  
 temperature: -40.0...+70.0  
 C: °C  
 stop limiters: <CR> <LF>  
 error code: 999.9

#### MESSAGE STRING WIMMB BAROMETRIC PRESSURE

Example of data sequence with comma separated fields: \$WIMMB,,,1050.0,B\*CS<CR><LF>  
 field delimiter: , (comma)  
 header: \$WIMMB  
 barometric pressure: 600.0...1100.0  
 B: air pressure in hPa  
 stop limiters: <CR> <LF>  
 error code: 9999.9

#### IMPORTANT! PLEASE NOTE:

##### FIELD LENGTH

The development of a NMEA decoder should not be proceeded from firm field lengths. The NMEA definition proceeds from a variable field length. The comma character (“,”) serves as field disconnecting switch. Numeric values in a field can be presented differently. In case a field is not sent, it has a length of 0 characters (,,) [comma-comma].

##### CHECK SUM

The check sum “CS” is covered to two ASCII characters hexadecimal value. “CS” calculated by XOR operation of each character in the sentence between “\$” and “\*”, but excluding “\$” and “\*”.

**MESSAGE STRING WIMHU RELATIVE HUMIDITY**

Example of data sequence with comma separated fields: \$WIMHU,100.0,, -40.0,C\*CS<CR><LF>  
 field delimiter: , (comma)  
 header: \$WIMHU  
 rel. humidity: 000.0...100.0  
 dew point temp.: -40.0...+70.0  
 C: °C  
 stop limiters: <CR> <LF>  
 error code: 999.9

**ERROR CODE**

In case, that the sensor cannot generate a measuring value because e.g. a sensor element is defect or implausible (raw) values are collected the sensor outputs in the corresponding data protocol the above mentioned error code (e.g. 999.9) and sets the status from "A" (valid) to "V" (not valid).

Example: \$WIMWV,999.9,R,999.9,M,V\*37<CR><LF>

## 17. Maintenance and service

**DEFINITIONS**

**Calibration** = Control measurement with a humidity standard

**Adjustment** = Calibration and additional readjustment of the probe to the setpoint value

**TEMPERATURE**

The sensor is adjusted before delivery. A temperature readjustment is usually not necessary. If there is any doubt about the correct adjustment, please contact the manufacturer.

**HUMIDITY**

The sensor is adjusted before delivery so that the results are in optimum accuracy over the full measuring range. We recommend testing the sensor **at least once a year** to maintain this accuracy.

**CLEANING**

Dirty sinter filters can cause measurement errors and extend the adjustment time. Depending on the degree of contamination of the sinter filters, they must be cleaned periodically or replaced if necessary.



**To avoid damaging the measuring elements, unscrew the sinter filter for cleaning.**

Clean the sinter filter with soapy water, alcohol, or a cleaning agent suitable for removing contamination and rinse thoroughly with water.

Do not screw the sinter filter back onto the probe until it is completely dry.



**Troubleshooting or maintenance and repair work may only be carried out by trained maintenance personnel who have completed appropriate training by the manufacturer.**

## 18. Upkeep and care

### REGULAR VISUAL INSPECTIONS

The producer recommends periodical visual checks of the sensor and shelter housing regarding outer damages, watertightness, and the fixing of the mounting screws, at intervals of **four weeks**.

### REPLACEMENT OF SPARE PARTS

Spare parts or replacement devices can be replaced using standard tools such as wrenches, screwdrivers, etc.

### ACCESSORIES AND SPARE PARTS LIST (PLEASE ORDER SEPARATELY)

ID	Description
00.08141.600000	Sensor shelter with natural ventilation
32.14567.060010	Cable 15 m, 4 pole
37.08095.000000	Sinter filter as sensor protection



### ORDERING SPARE PARTS

For a quick and error-free exchange or replacement delivery, please provide the following information to the manufacturer:

- Ident and serial number of the sensor
- Quantity required

### STORAGE AND DISPATCH

The sensor can be stored in a clean and dust-free environment at temperatures between  $-40...+70\text{ }^{\circ}\text{C}$  (non-condensing). The sensor should be kept in the manufacturer's original packaging, in which it is typically shipped. Alternative packaging must meet the standards of the original packaging and provide optimal protection against mechanical, electrical, as well as liquid or weather-related transport damage.

## 19. Download firmware and update

### DOWNLOAD FIRMWARE

On our website (<https://www.lambrecht.net>), the **Free Software Tools & Firmware** category can be found under **Service** in the **Resources** section. There you can easily download the latest firmware and the configuration software "THP Connect" for your product and benefit from ongoing improvements and new features.

### UPDATE FIRMWARE

With the configuration tool "THP Connect", the firmware of the THP[pro] can be easily updated. To do this, the sensor must be connected to the PC as described in "THP Connect - Configuration Tool" and "THP Connect" must be started.

The "Firmware update" tab can be selected in the left-hand area of the program window.

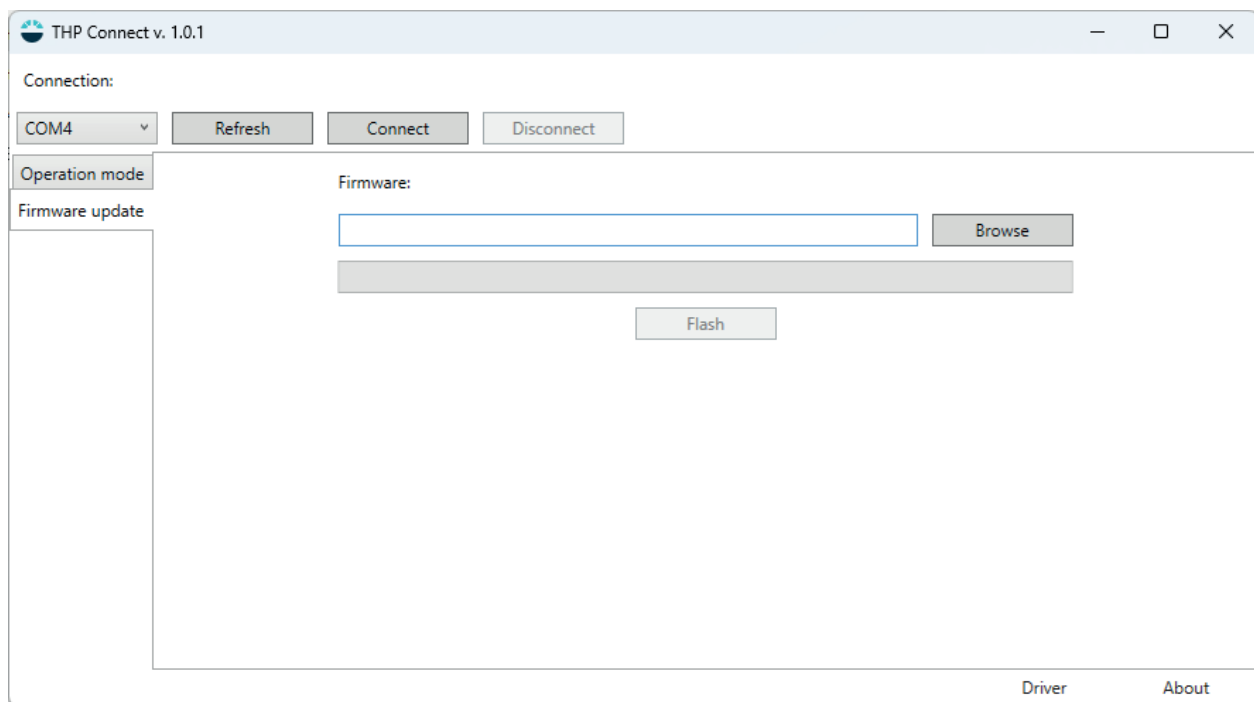

By clicking on "Browse," you can select the appropriate update file, which will be displayed in the adjacent field. After pressing the Flash button, the update will be loaded onto the THP[pro].



**CAUTION!** Do not switch off the PC or disconnect the USB plug before the update is complete. The progress can be tracked via the loading bar.

## 20. Disposal

LAMBRECHT meteo GmbH is listed and registered at the Stiftung Elektro-Altgeräte Register ear under:

**WEEE-Reg.-Nr. DE 45445814**

In the category of monitoring and control instruments, device type: "Monitoring and control instruments for exclusively commercial use".

### Within the EU



The device has to be disposed according to the European Directives 2002/96/EC and 2003/108/EC (Waste Electrical and Electronic Equipment). Do not dispose the old device in the household waste! For an environmentally friendly recycling and disposal of your old device, contact a certified disposal company for electronic waste.

### Outside the EU

Please follow the regulations in your country regarding the appropriate disposal of waste electronic equipment.

### \*) NOTE ON ACCURACY AND TOLERANCE SPECIFICATIONS (SEE CHAPTER 21)

Providing only the typical error is often insufficient in practice, as larger deviations can occur under certain conditions. To ensure reliable specifications, the maximum tolerance is indicated in addition to the typical tolerance (see figures).

These details allow for a realistic assessment of measurement accuracy under various operating conditions.

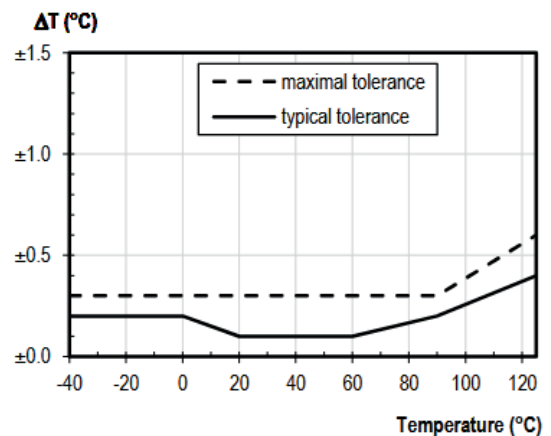
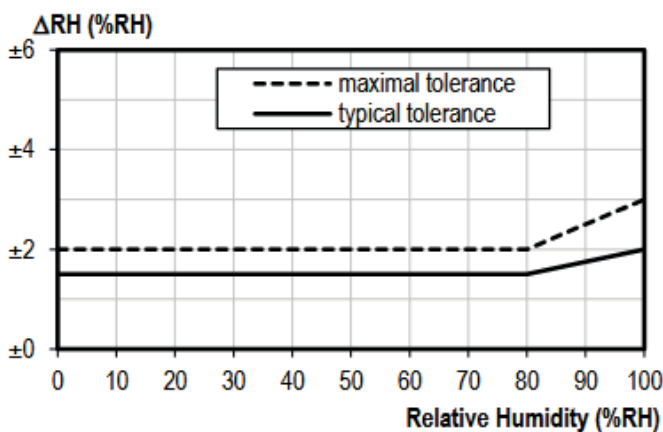

## 21. Technical data

COMPONENT	SPECIFICATION THP[PRO]
IDNo.	00.08095.300000
<b>TEMPERATURE</b>	
Measuring range	-40...+80 °C
Resolution	0.1 °C
Accuracy	± 0.1K (0...60 °C); ± 0.2K (-40...0 °C); ± 0.2K (60...70 °C)
<b>RELATIVE HUMIDITY</b>	
Measuring range	0...100 % RH
Resolution	0.1 % RH
Accuracy	Typically at 25 °C: ± 1% (20...70 %) r. h.; ± 1.5 % (0...20 %) RH; ± 1.5 % (70...90 %) r. h.; ± 3 % (90...100 %) RH
<b>BAROMETRIC PRESSURE</b>	
Measuring range	300...1200 hPa
Resolution	0.1 hPa
Accuracy	Typically ± 0.15 hPa; relatively ± 0.06 hPa
<b>FURTHER SPECIFICATIONS</b>	
Measuring elements	Temperature sensor; capacitive humidity sensor Air pressure sensors (3 independent pressure ICs, redundant)
Supply voltage	4.8...33 VDC
Power consumption	Low power mode: 1.1 mA at 12 VDC; 0.9 mA at 24 VDC
Interface	Serial RS-485; SDI-12
Protocol	Modbus RTU (preconfigured); SDI-12; NMEA
Standards	DIN EN 60945; DIN EN 61000-4-2, 3, 4, 6, 11
Housing / Protection class	Aluminum / IP65
Dimensions / Weight	H143 mm x Ø 20 mm / approx. 80 g
<b>ACCESSORY (please order separately)</b>	
IDNo. 00.08141.600000	Sensor shelter with natural ventilation
IDNo. 32.14567.060010	Cable 15 m, 4 pole
IDNo. 37.08095.000000	Sinter filter as sensor protection